

Date: 2004-09-10

Editor Bo Carlsson¹
IEA Solar Heating and Cooling Program
Task 27 Performance of Solar Façade Components
Project: Service life prediction tools for Solar Collectors

Recommended qualification test procedure for solar absorber surface durability

¹ Address: SP Swedish National Testing and Research Institute, P.O.Box 857, SE-50115 Borås, e-mail: bo.carlsson@sp.se

Contents

Page

Foreword.....	iv
Introduktion	v
1 Scope	1
2 Normative references	1
3 Terms and definitions	2
4 Requirements and classification.....	3
5 Test methods for assessing material properties as measure of absorber performance.....	4
5.1 Sampling and preparation of test specimens.....	4
5.2 Solar absorptance.....	4
5.3 Thermal emittance	4
5.4 Adhesion.....	4
6 Tests for assessing the thermal stability of absorber surface	4
6.1 Principle.....	4
6.2 Apparatus	6
6.3 Procedure for execution of high temperature tests	6
6.4 Qualification procedure	7
7 Tests for determining the resistance to condensed water of absorber surface.....	8
7.1 Principle.....	8
7.2 Apparatus	9
7.3 Procedure for execution of constant condensation tests	9
8 Test for determining absorber surface corrosion resistance to high humidity air containing sulphur dioxide.....	11
8.1 Principle.....	11
8.2 Apparatus	12
8.3 Reference test specimen	12
8.4 Procedure for execution of corrosion test in high humidity air containing sulphur dioxide ...	13
8.6 Qualification procedure	14
9 Report	14
Annex A (normative) Procedure for determination of solar absorptance and thermal emittance of absorber surface	15
A.1 Assessment of solar absorptance	15
A.1.1 Scope	15
A.1.2 Apparatus	15
A.1.4 Evaluation of spectral absorptance values.....	15
A.1.5 Evaluation of solar absorptance	16
A.1.6 Crucial factors in the assessment of solar absorptance.....	16
A.2. Assessment of thermal emittance	16
A.2.1 Scope	16
A.2.2 Apparatus	17
A.2.3 Assessment of thermal emittance	17
A.2.4 Crucial factors in the assessment of thermal emittance from spectral measurement	18
Annex B (normative) Temperature and failure time characteristics in assessment of thermal stability of absorber surface.....	19

Annex C (normative) Temperature/condensation and failure time characteristics together with qualification scheme in assessment of resistance to condensed water of absorber surface 23

Annex D (informative) Suitable designs for test apparatus to be used in the qualification testing of solar absorber surface 26

Annex E (informative) Bibliography 28

Foreword

This recommended qualification procedure is primarily based on the results of work performed on solar collector absorber surfaces within the framework of the International Energy Agency Program on Solar Heating and Cooling. The IEA work on solar collector absorber surfaces is reported in references given in Annex E.

Introduction

To effectively select, use and maintain a material in a given application, its degradation under service conditions must be predicted prior to use. Preferably, the durability of the material should be expressed quantitatively in terms of an expected service life. Durability in this case is the ability of a material to withstand deterioration caused by all external factors in the environment, which may influence the performance of the material under service conditions. Service life is defined as the period of time after installation during which specific material properties important for the performance of the material meet or exceed minimum acceptable values.

The service life of a material is, thus, not solely dependent on its physical and chemical properties, but also on its performance requirement in the application considered, and on the external environmental factors, which influence performance under service conditions. In design work, the important question is if a specific material can be expected to have a service life longer than a certain value, the so called design service life; the latter dictated by life cost considerations taking into account the total system. Service life assessment may be based on feed back data from practise or on results from so called qualification or acceptance durability tests.

The present recommended qualification procedure for solar absorber surface durability is based on the conduct of a series of short term durability tests. During a test the optical performance of the absorber surface tested is determined by measuring its solar absorptance and thermal emittance. From the loss in optical performance of the absorber surface, its failure time in the test performed is assessed and compared with the shortest acceptable failure time set by the design service life of the absorber. Design service life, performance requirement defining failure time in terms of loss in optical performance, classification of type and levels of environmental stress are set under the assumption, that the absorber surface tested will be installed in a flat plate solar collector for use in domestic hot water systems.

The recommended qualification procedure may favourably be used in the development and validation of new kinds of absorber surfaces. From the results of tests, it can be concluded whether it is likely that an absorber surface tested may meet the requirement for an acceptable service life also in practise. The recommended durability testing procedure has proved to give results in fairly good agreement, both qualitatively and quantitatively, with what has actually been observed on absorber surfaces tested for longer time periods in solar collectors working under typical domestic hot water system conditions.

Recommended qualification test procedure for solar absorber surface durability

1 Scope

This recommended procedure specifies a scheme of short term durability tests to be used in the qualification of absorber surfaces for the intended use in single glazed flat plate solar collectors for domestic hot water production.

An absorber surface is considered qualified if it meets the requirement of design service life of 25 years. The maximum loss in the optical performance of the absorber surface, defining its service life, is fixed at a level corresponding to a reduction in solar domestic hot water system performance, *i.e.* solar fraction, of 5 % in relative sense.

In the qualification procedure, the environmental factors considered the most important for the absorber surface durability are limited to temperature, humidity, and atmospheric corrosivity, the latter expressed in terms of concentration of sulphur dioxide in high humidity air. The program of short term durability tests is accordingly restricted to the simulation of three types of absorber surface degradation processes: a) high temperature degradation, b) degradation by the action of condensed water on the absorber surface, and c) degradation caused by high humidity in air containing a small concentration of sulphur dioxide as an airborne pollutant.

To quantify the expected environmental stress on the absorber surface determining its service life, microclimate data are utilized representing typical service conditions for absorbers in single-glazed flat plate collectors for domestic hot water production. For interpretation of the test results, time-transformation functions are used to relate intensities of the environmental factors under service conditions to that of the test conditions for the short-term durability tests. The requirement on the service life of the absorber surface may then be converted into acceptable failure times in the short-term tests. To conclude whether a specific absorber surface is qualified or not, requires a scheme of short-term tests of each category to be executed.

The recommended procedure is applicable for qualification of all kinds of absorber surface materials designed for flat plate collectors for the intended use of domestic hot water production. It is particularly suited for qualification of electroplated and sputtered selective absorber coatings for which the procedure was originally developed. If the absorber surface consists of an organic coating, *e.g.* a selective paint system, the effect of UV-degradation on optical performance of coating should be considered.

2 Normative references

The following referenced documents are indispensable for the application of this recommended procedure. For dated references, only the edition cited applies. For undated references, the latest edition of the referenced document (including any amendments) applies.

ISO 4624 – 1978 *Paints and varnishes - Pull-off test for adhesion*

ISO 9226 – 1992 *Corrosion of metals and alloys - Corrosivity of atmospheres - Determination of corrosion rate of standard specimens for the evaluation of corrosivity*

ISO 10062 - 1991 *Corrosion tests in artificial atmosphere at very low concentrations of polluting gas(es)*

ISO 8407 - 1991 *Corrosion of metals and alloys - Removal of corrosion products from corrosion test specimens*

ISO 9845 - 1:1992 *Solar Energy - Reference solar spectral irradiance at the ground at different receiving conditions. Part 1: Direct normal and hemispherical irradiance for air mass 1.5*

3 Terms and definitions

For the purpose of this recommended qualification procedure, the following definitions apply.

3.1 Design service life
The time period of exposure under service conditions after installation during which the absorber surface is expected to meet the performance requirement.

3.2 Failure time
The time period of exposure in the test during which the absorber surface meets the performance requirement.

3.3 Solar absorptance α_s
Fraction of solar radiation absorbed by absorber surface determined from measurement as is described in Annex A.

3.4 Thermal emittance ε
Near normal thermal emittance at 100 °C determined from measurement as is described in Annex A.

3.5 Performance criterion function PC
Quantity used for expressing the change in optical performance of absorber surface defined as:

$$PC = -\Delta\alpha_s + 0,50 \Delta\varepsilon \tag{1}$$

The change in the solar absorptance

$$\Delta\alpha_s = \alpha_{s,t} - \alpha_{s,i} \tag{2}$$

with $\alpha_{s,t}$ equal to the value of the solar absorptance at the actual time of the test or at service, and

with $\alpha_{s,i}$ equal to the initial value of solar absorptance

The change in the thermal emittance

$$\Delta\varepsilon = \varepsilon_t - \varepsilon_i \tag{3}$$

with ε_t equal to the value of the thermal emittance at the actual time of the test or at service and

with ε_i equal to the initial value of thermal emittance.

NOTE 1 This performance criterion function is primarily based on location averaged values of the performance of typical solar domestic hot water systems; see reference [1] in Annex E. But, in the IEA Task 10 testing procedure referred to a slightly different definition of PC is used, namely $PC = -\Delta\alpha_s - 0.25 \cdot \Delta\varepsilon$. Investigations made by the IEA MSTC group, however, showed that a weighting factor of 0.5 for the thermal emittance is more appropriate; see reference [6] in Annex E.

4 Requirements and classification

- 4.1 For classification of the durability of the absorber surface, the following performance requirement shall apply:

$$PC = - \Delta\alpha_s + 0,50 \Delta\varepsilon \leq 0,05 \quad (4)$$

NOTE 1 Higher values for the PC function may be used if considered more appropriate. $PC \leq 0,10$ should mean that the optical performance of absorber surface and, thus also the performance of solar domestic hot water system, is allowed to be reduced to a level equal to 90% of its original value during the design service life time period. For further details; see reference [1] in Annex E

- 4.2 Before durability testing of an absorber surface, all test specimens, sampled and prepared as described in subclause 5.1, shall be characterized with respect to their value for solar absorptance, determined as described in subclause 5.2, and their value for thermal emittance, determined as described in subclause 5.3.

To be qualified for testing, the set of test specimens shall have a standard deviation in the determined values for solar absorptance of less than 0,01 and for the determined values of thermal emittance a standard deviation less than 0,04.

- 4.3 For coated absorber surfaces, three extra test specimens shall be prepared and the adhesion of coating on those test specimens be assessed, as is described in subclause 5.4.

For the absorber to be qualified for testing, the adhesion of coating shall be $> 0,15$ MPa for all test specimens.

NOTE 3 If considered accurately enough, the adhesion of the coating may be assessed by a more simple method. The method of ISO 2409 Paints and varnishes - Cross-cut test may be used and the requirement for satisfactory adhesion be set at the degree of 0 or 1. Alternatively some suitable method in ISO 2819 Metallic coatings on metallic substrates - Electrodeposited and chemically deposited coatings - Review of methods available for testing adhesion may be used.

- 4.4 For an absorber surface to be qualified with respect to its thermal stability, the procedure of durability testing as is described in clause 6 shall be applied.

An absorber surface with sufficient thermal stability shall meet the requirement for test results as is specified in clause 6.4.

- 4.5 For an absorber surface to be qualified with respect to its resistance to condensed water when used in a non-airtight solar collector with more or less uncontrolled ventilation of air in the solar collector, the procedure of durability testing as is described in clause 7 shall be applied.

An absorber surface with sufficient resistance to condensed water shall meet the requirements for test results as are specified in subclause 7.4.

- 4.6 For an absorber surface to be qualified with respect to its resistance to degradation caused by sulphur dioxide as an airborne pollutant, the procedure of durability testing as is described in clause 8 shall be applied.

An absorber surface may be qualified for use in two classes of solar collectors; the two classes representing different severity classes as regards atmospheric corrosivity.

Solar collector of type A: Airtight solar collector or solar collector with controlled ventilation of air in the space between the absorber surface and the cover plate. At the top and at the bottom of the frame of collector, it should be equipped with ventilation holes. The atmospheric corrosivity at the bottom part of the collector under service conditions may typically correspond to a corrosion rate of zinc of $0,1 \text{ g/m}^2$ per year.

Solar collector of type B: Non-airtight solar collector with more or less uncontrolled ventilation of air in the solar collector. The atmospheric corrosivity at the bottom part of the collector under service conditions corresponds to a corrosion rate of zinc of 0.3 g/m^2 per year.

An absorber surface with sufficient resistance to degradation caused by sulphur dioxide in high humidity air, either regarding only a type A collector or regarding both type A and type B collectors, shall meet the requirements for test results as are specified in subclause 8.6.

5 Test methods for assessing material properties as measure of absorber performance

5.1 Sampling and preparation of test specimens

For durability testing, test panels with an absorber surface area of preferably 50x50 mm shall be prepared. Sampling from larger pieces of absorber plate shall be made in such a way that variation in the optical properties between the different test specimens is minimized. For execution of the complete programme of durability tests of this recommended procedure, a minimum of 21 test panels are required. For absorbers with coatings three extra test panels are also required for assessment of the adhesion of coating.

5.2 Solar absorptance

Determine the value of the solar absorptance for each of the 21 test panels from reflectance measurements as is described in Annex A.1. For the complete set of test panels calculate also the mean value and standard deviation of solar absorptance.

5.3 Thermal emittance

Determine also the value for the thermal emittance for each of the 21 test panels as is described in Annex A.2. For the complete set of test panels calculate also the mean value and the standard deviation of thermal emittance.

5.4 Adhesion

For coated absorber surfaces assess the adhesion of coating by making use of the three extra test panels prepared for this purpose. If the adhesion of coating is to be determined according to ISO 4624, use the general method for testing both rigid and deformable substrates when selecting test assembly and use test cylinders with a diameter of 20 mm. If a simpler method for assessment of adhesion is used, see subclause 4.3, proceed as described in the relevant standard.

6 Tests for assessing the thermal stability of absorber surface

6.1 Principle

6.1.1 High-temperature ageing is frequently used in many technical application areas for the assessment of thermal stability of materials. A high temperature accelerates all kinds of processes, normally leading to an increased rate of degradation of materials. For a selective absorber coating composed of small metal particles, a high temperature enhances oxidation of metal decreasing mainly the absorptance of coating.

6.1.2 When installed in a single flat plate collector for domestic hot water production, an absorber surface is exposed to a temperature, which may vary greatly; in the extreme case from $-20 \text{ }^\circ\text{C}$ up to more than $200 \text{ }^\circ\text{C}$. As a measure of the level of thermal load, the effective mean temperature, T_{eff} , during one year of service for an absorber surface is here used. It is defined by the following expression:

$$\exp \left(- \frac{E_T}{R} \cdot T_{\text{eff}}^{-1} \right) = \int_{T_{\text{min}}}^{T_{\text{max}}} \exp \left(- \frac{E_T}{R} \cdot T^{-1} \right) \cdot f(T) dT \quad (3)$$

$f(T)$ is yearly based frequency function for service temperature of absorber surface in solar collector, meaning the time fraction of a year when service temperature is in the interval T to $T+dT$.

T_{max} is the maximal service temperature of absorber surface in collector in K.

T_{min} is the minimal service temperature of absorber surface in collector in K.

E_T is the Arrhenius activation energy expressing the temperature dependence of a thermal degradation reaction of absorber surface.

R is the ideal gas law constant equal to 8,314 J/ K, mole

6.1.3 The yearly based frequency function $f(T)$ is determined by the external climatic load acting on the solar collector and the optical properties of the solar absorber surface and the glazing.

In this recommended procedure it is assumed that the solar collector is under operating conditions for 11 months of a year and then producing tap water during daytime when the solar collector temperature exceeds 40 °C. For one month of a year, during summer, the solar collector is under stagnation conditions. From a thermal ageing point of view it is only during the sunny days when the solar collector is under stagnation that the temperature load on the solar absorber surface will result in significant thermal degradation. The reference thermal load or temperature frequency function for one year representing service conditions in this recommended procedure corresponds therefore to 30 sunny days when the solar collector is under stagnation; see Figure B1 in Annex B.

The temperature load acting on the solar absorber surface depends also on the optical properties of the absorber surface and so does the maximum solar absorber surface temperature during stagnation conditions. The maximum solar absorber surface temperature is in this recommended procedure determined from the solar absorptance and the thermal emittance by use of interrelations shown in Table B1 in Annex B. The reference thermal load in terms of an effective mean temperature is thereafter calculated as a function of the activation energy for thermal degradation by making use of the maximum absorber surface temperature.

NOTE 1 If found more appropriate another temperature frequency function may be used to represent service conditions. The new effective mean temperature corresponding to a specific activation energy may be calculated by use of equation (3).

6.1.4 To assess the thermal stability of the absorber surface, short-term tests, enhancing thermal degradation of the absorber surface at a constant high temperature, are used. To convert the design service life of 25 years into a shortest acceptable failure time, y_R , for a constant temperature test to be executed at the temperature T_R , the following time-transformation function is used:

$$y_R = 25 \exp \left(- \frac{E_T}{R} \left(T_{\text{eff}}^{-1} - T_R^{-1} \right) \right) \quad (4)$$

where

T_{eff} in K is the effective mean temperature of absorber surface defined by equation (3). The effective mean temperature will vary with the activation energy and so will also the shortest acceptable failure time for a specific constant temperature test.

6.1.5 To conclude whether an absorber surface is qualified or not, the results from at least two different constant temperature tests are needed unless the optical performance of solar absorber surface tested is unaffected during the first test. The qualification scheme and the conditions for the temperature tests are given in Figures B2 - B4 and Table B2, respectively.

6.2 Apparatus

6.2.1 Testing chamber to be used for assessing the thermal stability of the absorber surface shall be constructed so that:

- 1) Constant temperature tests can be executed up to a temperature of at least 300 °C.
- 2) The temperature of the test is monitored by sensing devices in the chamber so that it reflects the true temperature of the test panels.

NOTE 1 Testing chambers with circulating air heating are recommended in favour of those based on radiative heating, because the temperature difference between the sensor and the test panels will be less due more uniform temperature condition in testing chambers of the former type.

NOTE 2 When radiative furnaces are used, the temperature of the test panels and the temperature of the temperature sensor strongly depend on the radiation exchange with the heater and therefore also on their optical properties. It is in this case preferable to measure the temperature of the test panel for heating control.

- 3) The temperature is maintained at level of $\pm 1^\circ\text{C}$ after stabilized conditions have been reached after start of test.

NOTE 3 Even a symmetrical variation around the set temperature results in a higher effective mean temperature with respect to thermal degradation.

- 4) The temperature in the chamber is so uniform that the variation between absorber specimens tested simultaneously is within the range of $\pm 1^\circ\text{C}$; see Note 1 and 2.
- 5) During cooling down of chamber after high temperature exposure, the rate of temperature decrease shall be at least 10 °C/min (from 200 °C to 100 °C). If the chamber does not meet this requirement, the test panels shall to be taken out of the chamber immediately after the specified testing time has been reached; see subclause 6.3.4.

6.2.2 Instruments for measuring of optical properties of absorber surfaces complying with the requirements as are specified in Annex A.

6.2.3 Tensile tester and test cylinders for measurement of adhesion of absorber coating in accordance with ISO 4624 as described in subclause 5.4. If a simpler method for assessment of adhesion is used, see subclause 4.3, use equipment complying with the requirements given in the relevant standard for assessment of adhesion.

6.3 Procedure for execution of high temperature tests

6.3.1 Select three test panels of absorber surface with known solar absorptance and thermal emittance and qualified for testing according to subclause 4.2.

6.3.2 Increase the temperature of the testing chamber to the specified level of test. After this temperature has been reached, place the test panels of room temperature in the testing chamber.

6.3.3 Keep the test panels at this temperature level for the specified time period of test.

6.3.4 After the specified time period of test or of interruption for measurement of extent of degradation, decrease the temperature of the testing chamber down to room temperature at a mean rate of minimum -10 °C/ min. during first phase of cooling down to 100 °C below the specified test temperature.

NOTE 4 If the testing chamber does not meet the requirement for minimum rate of cooling down as specified above, the test panels shall be taken out of the testing chamber immediately after the specified time period of test has been reached. The hot test panels shall after they have been taken out of the testing chamber be placed on a thermally insulating material to minimize damages, which may result from the thermal chock the test panels are exposed to during cooling down.

6.3.5 Determine the solar absorptance and the thermal emittance of test panels as is described in Annex A.

6.3.6 Calculate from the change in solar absorptance and thermal emittance of test panels, the value of the PC function for each panel tested by use of equation (1), see clause 3. Calculate also the mean value of the PC function for the different test panels.

6.3.7 If the test was interrupted only for measurement of extent of degradation, reintroduce the test panels after measurement into the climatic chamber after stabilized test conditions at the specified levels have been confirmed.

6.4 Qualification procedure

6.4.1 Determine from the mean values of the solar absorptance and the thermal emittance of the solar absorber surface to be tested the expected maximum absorber surface temperature T_{max} by use of Table B1 in Annex B; see also Figure B2 in Annex B

6.4.2 Determine from the T_{max} value the temperature T_1 of the first test to be performed making use of Table B2.

6.4.3 With a set of three test panels perform test, as described in clause 6.3, at T_1 and measure α_s and ε after the testing times 36, 75, 150, 300, and 600 h or till $PC = -\Delta\alpha_s + 0,50 \Delta\varepsilon > 0,05$ is reached. Introduce the time t_1 , which is the last testing/measuring time with $PC < 0,05$.

6.4.4 If $PC \leq 0,01$ after $t_1 = 600$ h the absorber surface is qualified with respect to its thermal stability if it meets also the requirement on satisfactory adhesion as specified in subclause 4.3.

6.4.5 If $PC > 0,05$ at $t_1 = 300$ h or $PC > 0,01$ after $t_1 = 600$ h check whether the absorber surface meets the adhesion requirement as specified in subclause 4.3. If the requirement on adhesion is met proceed as described in subclause 6.4.5.1. If the requirement on adhesion is not met the solar absorber surface is not qualified with respect to its thermal stability unless adhesion measurements performed on the solar absorber surface after a testing time corresponding to $PC = 0,05$ in a new test show that the adhesion requirement is met. Then, proceed as described in subclause 6.4.5.1.

6.4.5.1 Use Table B2 to determine the T_3 value which corresponds to the previously determined T_{max} value. Determine also from Table B2 the testing time t_3 which corresponds to the previously determined t_1 value; see also Figure B3 in Annex B

6.4.5.2 With a new set of three test specimens perform a test at T_3 for a time period of t_3 and measure α_s and ε to determine PC.

6.4.5.3 If $PC(T_3, t_3) \geq PC(T_1, t_1)$ the absorber surface is qualified with respect to its thermal stability.

6.4.6 If $PC > 0,05$ at $t_1 \leq 150$ h check whether the absorber surface meets the adhesion requirement as specified in subclause 4.3. If the requirement on adhesion is not met the solar absorber surface is not qualified with respect to its thermal stability unless adhesion measurements performed on the solar absorber surface after a testing time corresponding to $PC = 0,05$ in a new test show that the adhesion requirement is met. Then, proceed as described in subclause 6.4.6.1.

6.4.6.1 Use Table B2 to determine the T_2 value which corresponds to the previously determined T_{max} value. Determine also from Table B2 the testing time t_2 which corresponds to the previously determined t_1 value; see also Figure B4 in Annex B

6.4.5.2 With a new set of three test specimens perform a test at T_2 for a time period of t_2 and measure α_s and ε to determine PC.

6.4.5.3 If $PC(T_2, t_2) \leq PC(T_1, t_1)$ the absorber surface is qualified with respect to its thermal stability.

7 Tests for determining the resistance to condensed water of absorber surface

7.1 Principle

7.1.1 High humidity and the effect of moisture and condensed water on materials may initiate many kind of degradation reactions. Selective absorber coatings composed of inorganic oxides may sometimes undergo hydratization reactions increasing the thermal emittance of coating. High humidity must prevail for electrochemical corrosion to occur causing oxidation of metal and as a result the absorptance of coating may decrease.

7.1.2 As the casing of a flat plate collector is usually ventilated, this means that the absorber surface is in contact with the ambient air. Humid air from the ambient therefore enters the collector and sometimes the temperature of the collector inside is so low related to the humidity level that condensation of water takes place. As condensation of water appears in most of today's solar collectors, some collectors are not even rain tight, this means, an absorber surface has to resist periods of exposure in very humid atmospheres during its service life. An absorber surface should therefore to be qualified according to this procedure resist a humidity load representative for a non-airtight solar collector with more or less uncontrolled ventilation of air in the solar collector.

The yearly time fraction, when the relative air humidity in the gap between absorber and cover plate exceeds 99 %, is used as a measure of the severity of the humidity at service conditions. The severity depends, however, also on the effective mean temperature during such time periods of high humidity. The effective mean temperature during high humidity conditions is defined as in equation (3), see subclause 6.1.2. In this case equation (3) will, accordingly, contain the parameters given below with the following meaning:

$f_H(T)$ is the yearly based frequency function for service temperature of absorber surface in the solar collector when the relative humidity level exceeds 99%, meaning the time fraction of a year when service temperature is in the interval T to $T+dT$ and the relative humidity level exceeds 99%.

$T_{H,max}$ in K is the maximal service temperature of the absorber surface in the solar collector, when the relative humidity level exceeds 99%.

$T_{H,min}$ in K is equal to 0 °C, as below this temperature ice is formed on the surface of absorber.

$E_{H,T}$ is the Arrhenius activation energy expressing the temperature dependence for a possible degradation reaction of absorber surface caused by the action of condensed water.

In Figures C.1 in Annex C, the function $f_H(T)$ of this recommended procedure is shown.

NOTE If found more appropriate other humidity/ temperature data may be used to represent service conditions. The new effective mean temperatures for specific activation energy values may be calculated by use of equation (3).

7.1.3 To assess the resistance to condensed water of absorber surface, short-term tests at different temperatures of absorber surface are performed. To obtain constant condensation of water on the surface of absorber during testing, the surrounding air is kept at a temperature 5 °C above the temperature of absorber surface and at a relative humidity of 95%. To convert the design service life, set at 25 years, into a shortest acceptable failure time for a short term test, equation (4), see subclause 6.1.4, is also here applied.

In Figure C.2 in Annex C, the shortest acceptable failure time, as function of activation energy, is shown for a series of constant condensation tests.

7.1.4 To conclude whether an absorber surface is qualified or not, the results from at least two different constant condensation tests performed at two different temperatures are needed. For this recommended procedure the conduct of tests at absorber surface temperatures of 40 °C and 30 °C or at 40 °C and 60 °C are contained.

7.2 Apparatus

7.2.1 Climatic chamber to be used shall be constructed so that:

- 1) Climatic conditions ranging from room temperature and 50% RH up to at least 65 °C and 95% RH can be obtained, controlled and monitored during test.
- 2) The temperature can be maintained at a level of $\pm 1^\circ\text{C}$ and the relative humidity at a level of $\pm 3\%$ RH relative to the specified climatic conditions during test.

7.2.2 Liquid-cooled sample holder for temperature control of test panels in climatic chamber constructed so that:

- 1) The test panels can be fixed to it so that the test panels will be electrically insulated from each other and the sample holder.
- 2) The test panels will be in good thermal contact via the sample holder to the heat transfer liquid, which are used for cooling and control of the temperature of the test panel by aid of a thermostatic bath.
- 3) The test panels will be positioned at an angle of 45° relative to the horizontal plane.
- 4) The temperature of sample holder can be measured for control of test temperature. This can preferably be made by use of Pt 100 silicon foil sensor which adheres to the surface of the sample holder.

A suitable sample holder made of aluminium and which can be used for the purpose of this test is described in Annex D.

NOTE The crucial point in ensuring a high reproducibility of the condensation tests is the careful mounting of the test panels on the sample holder. A thin layer of an electrically insulating heat sink compound in combination with a foil for distance control, made of e.g. Teflon, can preferably be used to guarantee good thermal contact. The arrangement made means that bimetallic corrosion will be prevented too.

7.2.3 Thermostatic bath for temperature control of the liquid-cooled sample holder complying with the requirement of a temperature constancy over time for the sample holder of $\pm 0,5^\circ\text{C}$.

7.2.3 Instruments for measuring of optical properties of absorber surfaces complying with the requirements as are specified in Annex A.

7.2.4 Tensile tester and test cylinders for measurement of adhesion of absorber coating in accordance with ISO 4624, see subclause 5.4.

7.3 Procedure for execution of constant condensation tests

7.3.1 Select three test panels of absorber surface with known solar absorptance, thermal emittance, and qualified for testing according to subclause 4.2.

7.3.2 Adjust the temperature of the climatic chamber at a level of $5,0^\circ\text{C}$ above the specified test temperature for test panels and set the relative humidity level of climatic chamber at 95% RH. Adjust also the temperature of the thermostatic bath so that the temperature of the sample holder placed in the climatic chamber will reach the specified test temperature.

7.3.3 After stabilized conditions have been obtained, fix the test panels to the sample holder. The testing time period starts when condensation of water is first observed on the surface of the test panels.

7.3.4 After the specified time period of the test or of interruption for measurement of extent of degradation, take out the test panels from the climatic chamber and remove gently the excess of condensed water on the surface of the test panels by a clean water absorbing paper.

7.3.5 Condition the test panels under normal laboratory climatic conditions for at least 2 hrs. Determine the solar absorptance and the thermal emittance of the test panels as are described in Annex A.

7.3.6 Calculate from the change in solar absorptance and thermal emittance of the test panels, the value of the PC function for each panel tested by use of equation (1), see clause 3. Calculate also the mean value of the PC function for the different test panels.

7.3.7 If the test was interrupted only for measurement of extent of degradation, reintroduce the test panels after measurement into the climatic chamber after stabilized test conditions at the specified levels have been confirmed.

7.4 Qualification procedure

7.4.1 Perform a constant condensation test, involving exposure of the test panels at 40 °C with interruptions for measurement of extent of degradation after 80 hrs, 150 hrs, 300 hrs, and 600 hrs as described in subclause 7.3.

7.4.2 Dependent on the PC mean value obtained after 600 hrs of test proceed as follows:

If a coated absorber surface is tested check first whether the coating is qualified with respect to adhesion according to 7.4.3 and then

- 1) If $PC \leq 0,015$ the absorber surface is qualified with respect to its resistance to condensed water
- 2) If $0,015 < PC \leq 0,05$ proceed to subclause 7.4.9
- 3) If $PC > 0,05$ after 80 hrs of testing, perform a new test at 40 °C for 40 hrs. If $PC > 0,05$ after 150 hrs of testing, 300 hrs of testing, and 600 hrs of testing, perform new tests at 40 °C for 115 hrs, 225 hrs, and 450 hrs, respectively. Perform the new test without any interruptions for measurements until after the test is completed. After PC value has been determined after test, proceed to subclause 7.4.4

7.4.3 If a coated absorber surface is tested, measure, as described in subclause 5.4, the adhesion of coating on all test panels after that a PC mean value $> 0,05$ for the first time is obtained in the 40 °C constant condensation test or after 600 hrs of testing.

If the adhesion requirement as specified in subclause 4.3 is not met the absorber surface is not qualified with respect to its resistance to condensed water.

7.4.4 After that the mean value of PC has been found $> 0,05$ and a new 40 °C constant condensation test has been performed, estimate from the results by interpolation, the failure time, or in other words the testing time period, which should correspond to $PC = 0,05$. Use preferably, for this estimation a numerical or a graphical procedure, assuming PC plotted versus the testing time period can be represented by a polynomial series of an order which give the best fit to the test data obtained.

7.4.5 Use the estimated value of failure time for the 40 °C test and determine the corresponding or lowest acceptable activation energy from the 40 °C curve in Figure C.2 of Annex C.

7.4.6 Use this value for the activation energy and determine, from the 30 °C curve in Figure C.2 in Annex C, the corresponding or shortest acceptable failure time for the absorber surface in a test to be performed at 30 °C.

7.4.7 Perform, as described in subclause 7.3, a 30 °C constant condensation test for a testing time period corresponding to the shortest acceptable failure time period according to subclause 7.4.6.

7.4.8 Dependent on the PC mean value obtained after the 30 °C test, the following shall be concluded:

- 1) If $PC > 0,05$, the absorber surface is not qualified with respect to its resistance to condensed water.
- 2) If $PC \leq 0,05$, the absorber surface is qualified with respect to its resistance to condensed water.

7.4.9 If after 600hrs of test at 40 °C $0,015 < PC \leq 0,05$ according to subclause 7.4.2 execute a third kind of constant condensation test, involving exposure at 60 °C for a testing time period of 85 hrs, as described in subclause 7.3.

7.4.10 Dependent on the PC value obtained after the 60 °C test, the following shall be concluded:

- 1) If PC after 85 hrs in the 60 °C test $> PC$ after 600 hrs in the 40 °C test, the absorber surface shall be qualified with respect to its resistance to condensed water
- 2) If PC after 85 hrs in the 60 °C test $\leq PC$ after 600hrs in the 40 °C test, it can not be concluded whether the absorber surface shall be considered qualified or not and, therefore, a more comprehensive investigation on its resistance to condensed water is recommended.

7.4.11 The qualification procedure to be used is schematically shown in Figure C.3 in Annex C.

8 Test for determining absorber surface corrosion resistance to high humidity air containing sulphur dioxide

8.1 Principle

8.1.1 Many air borne pollutants, such as sulphur dioxide present in air as a trace substance, accelerates highly, as well known, electrochemical corrosion of most metallic materials at high humidity. As a solar collector exchanges air with the ambient, this means also that air borne pollutants will be transported from the ambient into the collector and the absorber surface. Airborne pollutants may, therefore, influence the long-term optical performance of an absorber by promoting corrosion attacks on the metallic substrate. Air borne pollutants may also cause loss in the optical performance of selective absorber coatings pigmented with small metallic particles, due to oxidation/corrosion of the metal particles.

8.1.2 Due to the complex nature of degradation caused by air pollutants, atmospheric corrosivity, as defined from exposure of standard panels of metals as described in ISO 9226, is here used. More precisely, the corrosion rate of zinc is taken as a measure for severity of environmental stress on absorber surface in collectors and sulphur dioxide is considered the dominating air borne pollutant as regards degradation of absorber surface. As described in subclause 4.6, two severity classes are here used related to two kinds of collectors for which corrosion rates for zinc are defined.

NOTE 1 If found more appropriate other levels of atmospheric corrosivity may be used to represent service conditions. The new levels of atmospheric corrosivity may be expressed also in terms of corrosion rates of other metal than zinc, if found more appropriate.

8.1.3 To assess the atmospheric corrosion resistance of the absorber surface, exposure in high-humidity air containing small concentrations of sulphur dioxide (1 ppm) is adopted. To convert the design service life of 25 years into shortest acceptable failure times relevant for the two severity classes defined, the principle of comparative testing is applied. This means that the time transformation function for degradation of optical performance of absorber surface is assumed to be the same as the one for the corrosion of zinc.

NOTE 2 In the study of nickel pigmented anodized aluminium absorber coatings as described in reference [1] of Annex E, it was roughly assumed that the time transformation function for degradation of the nickel-pigmented anodized aluminium coatings was the same as for the corrosion of zinc. The reasonableness of this assumption was supported by results from measurements of deposited amounts of sulphur dioxide on this kind of coatings both during laboratory tests, involving exposure in high humidity air containing sulphur dioxide, and during in-service tests of absorbers in collector; see also reference [4] in Annex E.

8.1.4 To conclude whether an absorber surface is qualified or not, the results from one test, involving exposure in circulating air of a relative humidity of 95% RH, temperature of 20 °C, and with a volume fraction of sulphur dioxide of 10^{-6} , are needed. The test is essentially performed as described in ISO 10062.

8.2 Apparatus

8.2.1 Climatic cabinet with inner chamber and gas flow system, shall comply with the requirements of ISO 10062. An example of a suitable design is shown in Annex D.

The equipment used for testing shall be constructed so that:

- 1) The inner chamber and gas flow system consist of inert materials, e.g. Teflon or glass, to avoid or minimize adsorption of sulphur dioxide on surfaces other than that of the test panels.
- 2) The air flow and sulphur dioxide injection system are designed to ensure uniform test conditions in the inner chamber or working space of the cabinet.

NOTE1 In the most common design of test equipment, the test atmosphere in the working space is obtained by continuously introducing the necessary quantity of sulphur dioxide into a damp air flow to obtain the required concentration. Sulphur dioxide and conditioned air are mixed outside the cabinet. The conditioned air is taken from the outer chamber of the climatic cabinet. The air flow after injection of sulphur dioxide is then mixed with a flow of recirculated test atmosphere and the resulting gas flow admitted into the inner chamber or working space of the cabinet. Half of the flow of the test atmosphere through the inner chamber may be recirculated.

To ensure uniform test conditions in the working space, the test atmosphere is normally supplied to the working space from the bottom and the outlet is placed at the top. Perforated plates are placed in front of the openings to assure uniform air flow through the working space.

- 3) Uniformity of temperature in the working space shall be better than ± 1 °C and uniformity of relative humidity better than ± 3 %. In terms of corrosivity, as expressed in terms of corrosion rates of standard metals, the uniformity shall be not less than 5%.

NOTE 2 The uniformity of the test conditions in the working space may be checked regularly by exposing a number of copper coupons, placed at different positions in the working space during sulphur dioxide exposure. The differences in weight change of the metal coupons indicate if the uniformity of test conditions is within specified range.

- 4) The damp air flow shall be within the tolerance for the specified temperature ± 1 °C and relative humidity $\pm 3\%$ and the linear flow rate of air shall be in the range of 1 mm/s to 5 mm/s. The damp air flow shall be free of water droplets or aerosols.

NOTE 3 - In the most common design of test equipment, the air is introduced to the outer chamber of the cabinet after filtration and purification by activated charcoal and a particulate filter. The sulphur dioxide gas may be taken from a pressurized cylinder filled with high-purity sulphur dioxide gas at a volume fraction of 10^{-3} in high-purity nitrogen gas.

- 5) For exposure of test panels in the working space, specimens holder shall be used so the test panels do not shield one another or disturb the uniformity of the flow of air across the chamber.
- 6) The temperature, relative humidity, and concentration of sulphur dioxide in the air flow at the outlet of the working space is monitored so that they reflect the true test conditions for the test panels.

8.2.2 Instruments for measuring of optical properties of absorber surfaces complying with the requirements as are specified in Annex A.

8.2.3 Tensile tester and test cylinders for measurement of adhesion of absorber coating in accordance with ISO 4624; see subclause 5.4.

8.3 Reference test specimen

For measurement of corrosivity in the working space during testing, standard test panels of zinc shall be used.

The test panel of zinc may preferably has a dimension of 50 mm x 100 mm x 1 mm, and shall have an impurity level at or lower than 0,5 %.

Before testing the test panels shall carefully be cleaned with a hydrocarbon solvent in order to remove all marks of dirt, oil, or other foreign matter capable of influencing the result from the corrosion rate determination. After drying the panel shall be possible to weigh to the nearest 0,1 mg.

After testing the corrosion products on the zinc panel shall be removed as described in ISO 8407 and the mass loss of the metal be determined. Use for removal of corrosion products a solution with a mass fraction of 5% of acetic acid in distilled water. During chemical removal of corrosion products work at room temperature with cleaning cycles with a length of around 2 min. Express mass loss of metallic zinc in mg / m^2 .

8.4 Procedure for execution of corrosion test in high humidity air containing sulphur dioxide

8.4.1 Select three test panels of absorber surface with known solar absorptance, thermal emittance, and qualified for testing according to subclause 4.2.

8.4.2 Prepare the climatic cabinet for test by firstly adjusting temperature to 20 °C, air humidity to 95% RH and air flow rate at a selected value between 1 mm/s and 5 mm/s. After stable conditions have been reached, adjust the sulphur dioxide gas flow to the specified level so that the sulphur dioxide volume fraction in the inlet air flow to the working space will be at a level of 10^{-6} .

8.4.3 When stabilized conditions have been reached also after this step, open the door to cabinet and place the test and reference panels quickly in the working space. After a testing time period not more than 5% of the specified time period of test, the concentration of sulphur dioxide in the outlet air flow from the working space shall not be less than 90% of that in the inlet flow of air. If the concentration of sulphur dioxide in the outlet air flow is lower, this probably means the total area of the test panels in the cabinet is too large. During the test, check the exposure conditions regularly and, if necessary, make adjustments to the specified levels.

8.4.4 After the specified time period of test or interruption for measuring the extent of degradation in optical performance of the test panels, take out the test panels from the working space of the cabinet and place them in a desiccator over silica gel for at least 2 hrs. Determine the solar absorptance and the thermal emittance of the test panels as are described in Annex A.

8.4.5 Calculate from the change in solar absorptance and thermal emittance of the test panels, the value of the PC function for each panel tested by use of equation (1), see clause 3. Calculate also the mean value of the PC function for the different test panels.

8.4.6 If the test was interrupted only for measurement of extent of degradation, reintroduce the test panels after the measurement into the working space after stabilized test conditions at the specified levels have been confirmed.

8.5 Determination of shortest acceptable failure times in test by use of reference test specimens

8.5.1 If the corrosion rate of zinc, under the test conditions specified in subclause 8.4, is not known from previous exposures in the test equipment used, proceed as follows.

8.5.2 Perform a corrosion test as described in subclause 8.4 with three pairs of reference test panels of zinc with known initial mass, see subclause 8.3. Make interruptions of the test after 90 hrs, 180 hrs and 360 hrs and take out from cabinet at each interruption of test one pair of zinc panels for determination of mass loss in metallic zinc caused by corrosion during test, see subclause 8.3.

8.5.3 Assume the mass loss in metallic zinc versus the testing time period is linear and determine by least square fitting, the mean corrosion rate of zinc, r_{Zn} , during the test conditions specified in subclause 8.4. Express r_{Zn} in $\text{mg} / \text{m}^2, \text{h}$.

8.5.4 Use the mean corrosion rate of zinc and determine the following shortest acceptable failure times in hrs of the test according to subclause 8.4 as:

1) For a type A solar collector, see clause 4: Shortest acceptable failure time, $t_{f,A} = 2.5 / r_{\text{Zn}}$

- 2) For a type B solar collector, see clause 4: Shortest acceptable failure time $t_{f,B} = 7,5 / r_{Zn}$

8.6 Qualification procedure

8.6.1 Perform a corrosion test as specified in subclause 8.4 for $t_{f,B}$ hrs, including also one interruption of the test for measurement of extent of degradation after $t_{f,A}$ hrs. If only qualification for the type A solar collector severity class is required complete the test after $t_{f,A}$ hrs.

8.6.2 If a coated absorber surface is tested, measure, as described in subclause 5.4, also the adhesion of the coating on all the panels after the test.

If the requirement on adhesion as specified in subclause 4.3 is not met the absorber surface is not qualified with respect to long-term performance.

8.6.3 Dependent on the PC mean value obtained after the two testing times of subclause 8.6.1, the following shall be concluded regarding corrosion resistance of absorber surface:

- 1) If after $t_{f,A}$ hrs of test, $PC < 0,05$, the absorber surface is qualified for the type A solar collector severity class, if, when coated, it also fulfils the requirement of subclause 8.6.2.
- 2) If after $t_{f,B}$ hrs of test, $PC < 0,05$ too, the absorber surface is qualified also for the type B solar collector severity class, if, when coated, it also fulfils the requirement of subclause 8.6.2.

9 Report

The test report shall give the following information.

- a) Reference to this recommended procedure
- b) The type and designation of the tested product of absorber surface
- c) Any deviations from the prescribed testing method
- d) Method for assessing adhesion if appropriate and used requirement for acceptable adhesion
- e) Test results
- f) Testing laboratory
- g) Dates for start and completion of tests

Annex A (normative)

Procedure for determination of solar absorptance and thermal emittance of absorber surface

A.1 Assessment of solar absorptance

A.1.1 Scope

This procedure specifies a method for determination of the directional solar absorptance α_S , for near-normal incidence, *i.e.* 8° to 10° to the surface normal, from spectral directional absorptance $\alpha(\lambda)$ values in the spectral range of $0.32 \mu\text{m}$ - $2.5 \mu\text{m}$. The spectral directional absorptance $\alpha(\lambda)$ values are determined from spectral (near-normal) directional/hemispherical reflectance $\rho(\lambda)$ values measured on opaque samples of solar absorber surfaces at room temperature.

A.1.2 Apparatus

Spectral (near-normal) directional/hemispherical reflectance $\rho(\lambda)$ values shall be determined by photometric integration by use of a spectrophotometer equipped with an integrating sphere. The wall of sphere shall be coated with a highly and diffusely reflecting coating, *e.g.* BaSO_4 . In the photometric integration the specular component of reflected radiation has to be included.

The sphere shall be designed so that the sample is part of sphere wall during the measurement. The detector shall be positioned so that it is shielded against radiation received directly from the sample.

The geometry of the sphere shall preferably be so that the comparison method can be used, *i.e.* sample and reference are simultaneously part of the sphere wall.

NOTE 1 When using the substitution method, *i.e.* sample and reference are alternately covering the measuring port, the sphere error must be corrected for by measuring the respectively corresponding brightness of the sphere wall.

For calibration purposes, freshly pressed BaSO_4 powder or a diffusely reflecting white tile shall be used as reference.

A.1.3 Measurement of reflectance values

Solar absorptance shall to be assessed by use of the weighted ordinates method; see A.1.5.

The reflectance shall be measured at at least 40 wavelengths in the range $0,32 \mu\text{m}$ - $2,50 \mu\text{m}$.

A.1.4 Evaluation of spectral absorptance values

Calculate the near normal/hemispherical spectral reflectance of sample, $\rho(\lambda)$, by use of the following expression:

$$\rho(\lambda) = (R_S(\lambda) / R_R(\lambda)) \cdot \rho_R(\lambda) \quad (\text{A.1})$$

where

$R_S(\lambda)$ is the recorded reflectance value of sample.

$R_r(\lambda)$ is the recorded reflectance value of reference.

$\rho_r(\lambda)$ is the near-normal / hemispherical reflectance of reference.

NOTE 2 - Values for the spectral near normal / hemispherical reflectance of reference can in case of freshly pressed BaSO₄ powder be found in the literature, see for example reference [7] in Annex E. If a diffusely reflecting white tile is used as reference, $\rho_r(\lambda)$ values should be available from manufacturer or be determined by own measurement using freshly pressed BaSO₄ powder as a reference.

As no correction of possible distortion of the measured result when a specular component of the reflected radiation exists, the spectral directional absorptance $\alpha(\lambda)$ value are calculated as:

$$\alpha(\lambda) = 1 - \rho(\lambda) \quad (\text{A.2})$$

A.1.5 Evaluation of solar absorptance

The solar absorptance, α_s , is calculated from the following expression::

$$\alpha_s = \left(\sum_{i=1}^n (\alpha(\lambda_i) \cdot S_{\lambda_i}) \right) / \left(\sum_{i=1}^n S_{\lambda_i} \cdot \Delta\lambda_i \right) \quad (\text{A.4})$$

where

the set of λ_i are the selected measuring wavelengths.

$\Delta\lambda_i$ is the respective wavelength interval.

S_{λ_i} is the spectral solar irradiance according to ISO 9845, correctly summed over the respective wavelength interval.

A.1.6 Crucial factors in the assessment of solar absorptance

When assessing the solar absorptance of absorber surface according to this procedure, attention shall be paid to:

- 1) Possible anisotropy of the samples, i.e. the samples shall be marked to allow mounting of the samples at the measuring port using the same orientation and ensuring that the same areas of samples are measured. When establishing degradation-over-time relationships in an durability test, measurements of extent of degradation at different testing times should be performed on one and the same sample.
- 2) The different weighting of different directions of polarisation by the monochromators may distort the measurement, although this is not a great effect for near-normal incidence.

A.2. Assessment of thermal emittance

A.2.1 Scope

This procedure specifies methods for determination of

- 1) total directional emittance ε_n (100 °C) for near-normal incidence

- 2) spectral near-normal directional emittance $\varepsilon(\lambda)$, and
- 3) total hemispherical emittance $\varepsilon_h(100\text{ }^\circ\text{C})$.

These quantities are elaborated from measurements of

- 1) total hemispherical/directional reflectance $\rho(100\text{ }^\circ\text{C})$ for thermal radiation incident from a black-body radiator of $100\text{ }^\circ\text{C}$, yielding $\varepsilon_h(100\text{ }^\circ\text{C})$, or
- 2) total directional emittance $\varepsilon(100\text{ }^\circ\text{C})$ of heated samples, yielding $\varepsilon_h(100\text{ }^\circ\text{C})$, and
- 3) spectral directional / hemispherical reflectance $\rho(\lambda)$ firstly yielding the directional spectral emittance $\varepsilon_h(\lambda)$ and by weighted integration with a Planck-distribution for a black body radiator at a chosen temperature, T , yielding finely $\varepsilon_h(T)$

Whenever the reflection method is used, transmittance has to be zero within spectral range measured.

The spectral range is $2.0\text{ }\mu\text{m} - 50.0\text{ }\mu\text{m}$. The angle of incidence or emission is restricted to near-normal, i.e. 8° to 10° to the surface normal. The temperature of sample is $100\text{ }^\circ\text{C}$ in radiometric measurements on heated samples, and is room temperature when using the reflection method.

A.2.2 Apparatus

For determination of emittance quantities from spectral measurements, use for photometric integration a spectrophotometer equipped with diffusely reflecting gold coating as sphere wall. In photometric integration the specular component of reflected radiation shall be included.

The requirements on sphere design is the same as described in subclause A.1.2.

For calibration purposes, the following references are recommended:

- a) For broadband measurements, use reference Nextel Velvet Coating 2010 black (American indication: Nextel 101 - C10) with $\varepsilon_h(100\text{ }^\circ\text{C}) = 0.95$ and $\varepsilon_h = 0.90$

NOTE 1 Emittance values refer to measurements made by J. Lohrengel, PTB Braunschweig, Germany.

NOTE 2 For Devices and Services Emissiometer Model AE, use the references delivered by manufacturer with the instrument.

- c) For spectral measurements, as reference Labsphere diffusely reflecting gold coating "Infragold".

NOTE 3 Recommended reference with calibration certificate available from Labsphere Inc., North Sutton, NH 03260, USA

A.2.3 Assessment of thermal emittance

- a) For assessment based on broad-band measurements, use the procedure given by manufacturer of measuring instrument.
- b) For assessment based on spectral measurements in the wavelength range $2.0\text{ }\mu\text{m} - 50.0\text{ }\mu\text{m}$, use the following procedure.

Calculate the near normal/hemispherical spectral reflectance of sample, $\rho(\lambda)$, by use of the following expression:

$$\rho(\lambda) = (R_S(\lambda) / R_R(\lambda)) \cdot \rho_R(\lambda) \quad (\text{A.5})$$

where

$R_S(\lambda)$ is the recorded reflectance value of sample.

$R_R(\lambda)$ is the recorded reflectance value of reference.

$\rho_R(\lambda)$ is the near-normal / hemispherical reflectance of reference.

As no correction of possible distortion of the measured result when a specular component of the reflected radiation exists, calculate the spectral directional emittance, $\varepsilon(\lambda)$, as:

$$\varepsilon(\lambda) = 1 - \rho(\lambda) \quad (\text{A.6})$$

Convolute the total emittance from spectral measurements, $\varepsilon(100^\circ\text{C})$, with the aid of the Planck function P_λ for a black-body radiator with temperature of 100°C , as:

$$\varepsilon(100^\circ\text{C}) = \left(\int_0^\infty \varepsilon(\lambda) \cdot P_\lambda \, d\lambda \right) / \left(\int_0^\infty P_\lambda \, d\lambda \right) \quad (\text{A.6})$$

NOTE Values for the Planck function can be found for example in most handbooks in physics.

A.2.4 Crucial factors in the assessment of thermal emittance from spectral measurement

When assessing the thermal emittance of absorber surface from spectral measurements, attention shall be paid to the same factors as are described in subclause A.1.6.

Annex B (normative)

Temperature and failure time characteristics in assessment of thermal stability of absorber surface

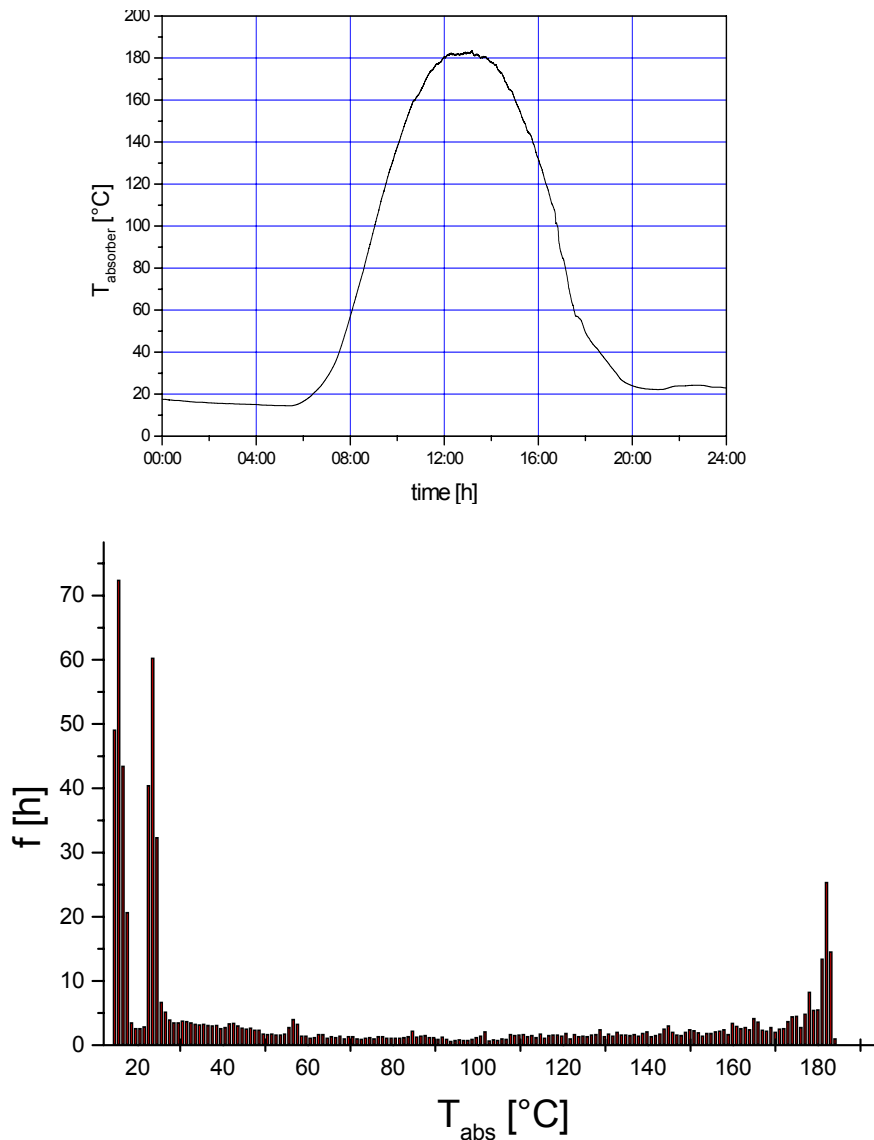

Figure B.1 Reference thermal load for assessment of thermal stability of absorber surface (a) Measured solar absorber surface temperatures at stagnation condition during one day of clear sky conditions (b) Corresponding temperature frequency function for 30 days with clear sky conditions.

The temperature profile of the selective absorber surface ($\alpha_s = 0.94$ and $\varepsilon = 0.06$) was measured in a commercial flat plate collector installed in Freiburg/Germany, facing south with a tilt angle of 45° . The profile was recorded 25th of August 1997 with a maximum global radiation of about 930W/m^2 , measured in the collector plane. The maximum stagnation temperature was 184°C .

Table B.1 Relation between the maximum solar absorber surface temperature T_{max} and the optical properties of the solar absorber surface to be tested. The line entitled "AR α " has to be used for solar absorber surfaces that will be used in solar collectors with antireflective glazing leading to higher stagnation temperatures.

α	1	0.99	0.98	0.97	0.96	0.95	0.94	0.93	0.92	0.91	0.9	0.89	0.88	0.87	0.86	0.85	0.84	0.83	0.82	0.81	0.8	0.79	0.78	0.77	0.76	0.75	0.74	0.73	0.72	0.71	0.7	0.69	0.68	0.67	0.66	0.65	0.64	0.63	0.62	0.61																																																																																																																																																																																		
0	238	236	235	233	231	229	228	226	224	222	220	219	217	215	213	211	210	208	206	204	202	200	199	197	195	193	192	190	188	186	184	182	180	179	177	175	173	172	170	169	167	166	165	164	163	162	161	160	159	158	157	156	155	154	153	152	151	150	149	148	147	146	145	144	143	142	141	140	139	138	137	136	135	134	133	132	131	130	129	128	127	126	125	124	123	122	121	120	119	118	117	116	115	114	113	112	111	110	109	108	107	106	105	104	103	102	101	100	99	98	97	96	95	94	93	92	91	90	89	88	87	86	85	84	83	82	81	80	79	78	77	76	75	74	73	72	71	70	69	68	67	66	65	64	63	62	61	60	59	58	57	56	55	54	53	52	51	50	49	48	47	46	45	44	43	42	41	40	39	38	37	36	35	34	33	32	31	30	29	28	27	26	25	24	23	22	21	20	19	18	17	16	15	14	13	12	11	10	9	8	7	6	5	4	3	2	1	0	0.1	0.2	0.3	0.4	0.5	0.6	0.7	0.8	0.9	1

Table B.2 Test conditions for the different accelerated temperature tests used in the qualification of solar absorber surface

T_{max} (°C)	T₁ (°C)	T₂ (°C)	t₂ (h) (t₁ =18 h)	t₂ (h) (t₁ =36 h)	t₂ (h) (t₁ =75 h)	t₂ (h) (t₁ =150 h)	T₃ (°C)	t₃ (h) (t₁ =300 h)	t₃ (h) (t₁ =600 h)
<90	137	107	361	493	689	953	167	83	221
91-100	149	119	321	443	627	877	179	88	233
101-110	160	130	283	397	570	808	190	93	244
111-120	172	142	251	356	519	746	202	98	256
121-130	184	154	222	320	474	690	214	103	267
131-140	196	166	198	289	434	641	226	108	278
141-150	208	178	177	262	400	598	238	114	289
151-155	215	185	168	250	384	578	245	116	294
156-160	221	191	159	239	369	559	251	119	299
161-165	227	197	151	229	355	542	257	121	304
166-170	233	203	144	219	342	525	263	124	309
171-175	240	210	137	210	330	510	270	127	314
176-180	246	216	131	201	319	495	276	129	319
181-185	252	222	125	193	308	481	282	132	323
186-190	259	229	120	186	298	468	289	134	328
191-195	265	235	114	179	289	456	295	136	333
196-200	272	242	110	173	280	444	302	139	337
201-205	278	248	105	166	272	433	308	141	342
206-210	285	255	101	161	264	423	315	144	346
211-215	291	261	97	155	256	413	321	146	350
216-220	298	268	94	150	249	403	328	148	355
221-225	304	274	90	146	243	394	334	151	359
226-230	311	281	87	141	236	386	341	153	363

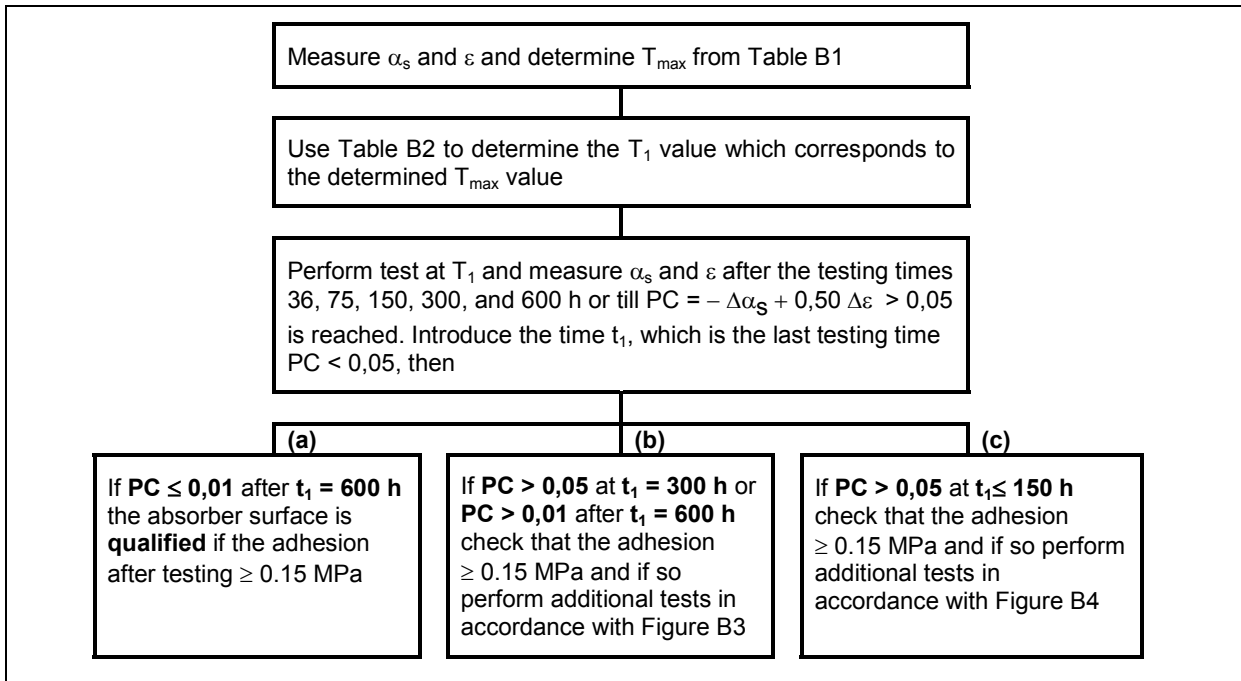

Figure B2 Qualification scheme for testing the thermal stability of solar absorber surfaces

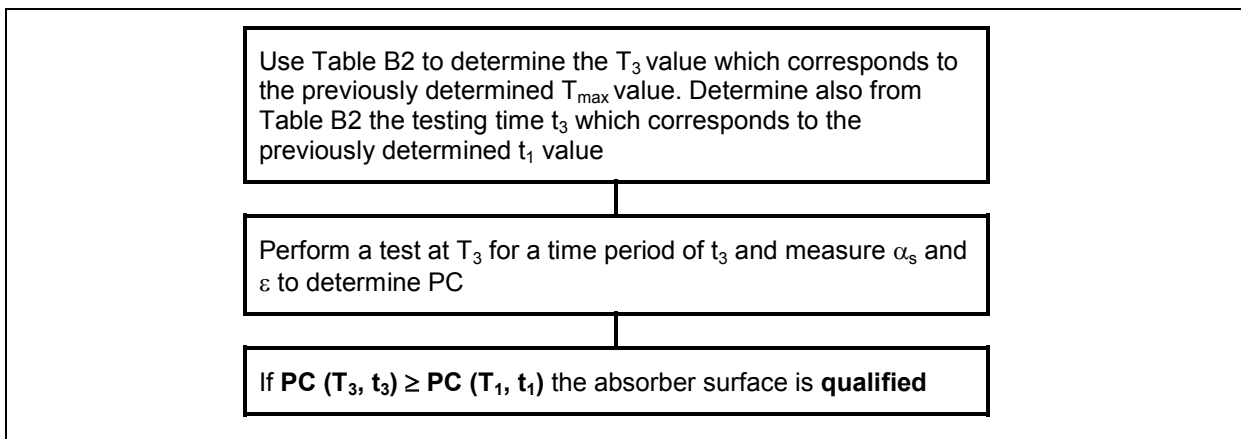

Figure B3 Continuation of the qualification scheme in Figure B2 for the (b) option

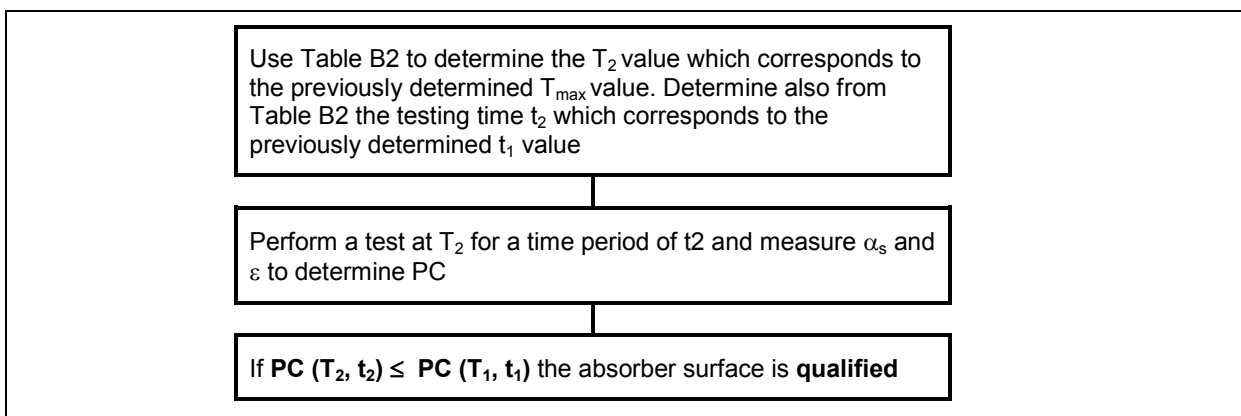

Figure B4 Continuation of the qualification scheme in Figure B2 for the (c) option

Annex C (normative)

Temperature/condensation and failure time characteristics together with qualification scheme in assessment of resistance to condensed water of absorber surface

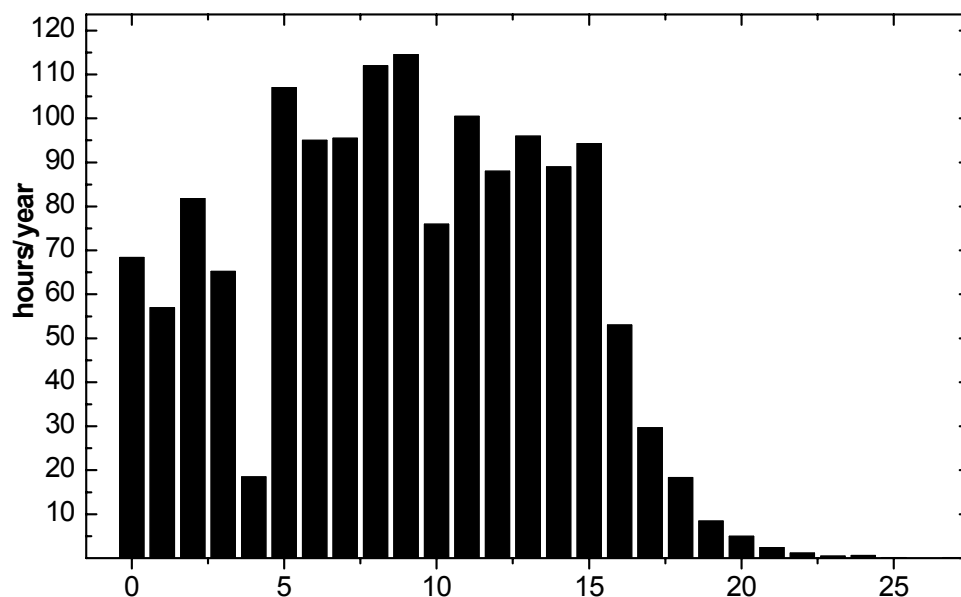

Figure C.1 Reference humidity/condensation yearly load used in this recommended procedure. The temperature frequency function represents the conditions when $RH \geq 99$ during the reference year.

Table C.1 Numerical data for the reference temperature frequency function f given in Figure C.1

Temp.(°C)	f (h/year)	Temp.(°C)	f (h/year)	Temp.(°C)	f (h/year)	Temp.(°C)	f (h/year)
-5	0,00	3	17,53	11	48,58	19	2,75
-4	0,67	4	32,31	12	38,98	20	2,83
-3	2,17	5	41,33	13	49,88	21	1
-2	6,08	6	21,98	14	56,83	22	0,33
-1	14,13	7	34,13	15	54,06	23	0,17
0	39,30	8	35,09	16	32,66	24	0,17
1	26,66	9	34,43	17	17,28	25	0,00
2	35,88	10	19,88	18	6,09		

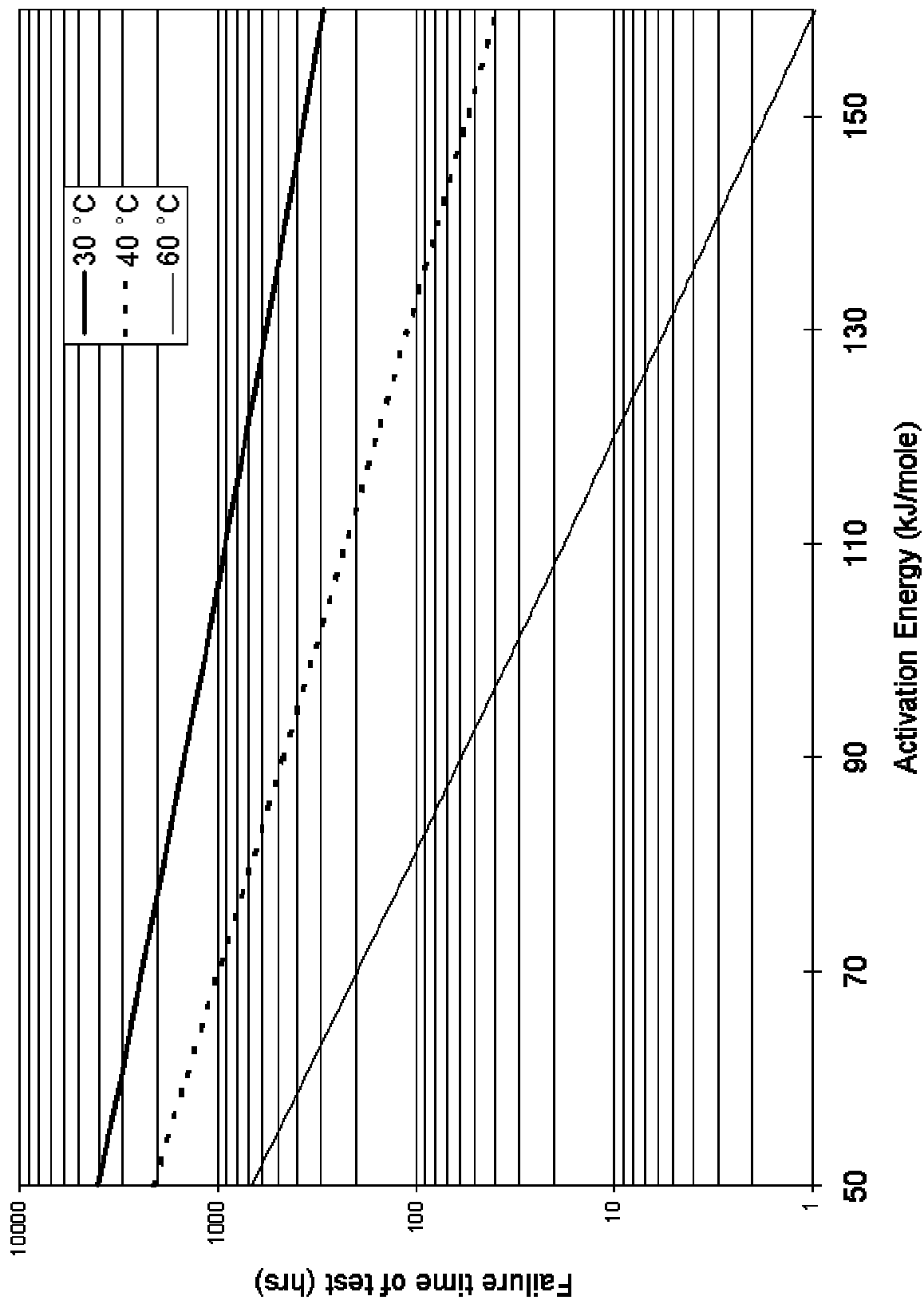

Figure C.2 Shortest acceptable failure time for absorber surface in different condensation tests given as a function of the activation energy for the degradation reaction. The failure time given corresponds to a service life with PC < 0,05 of 25 years.

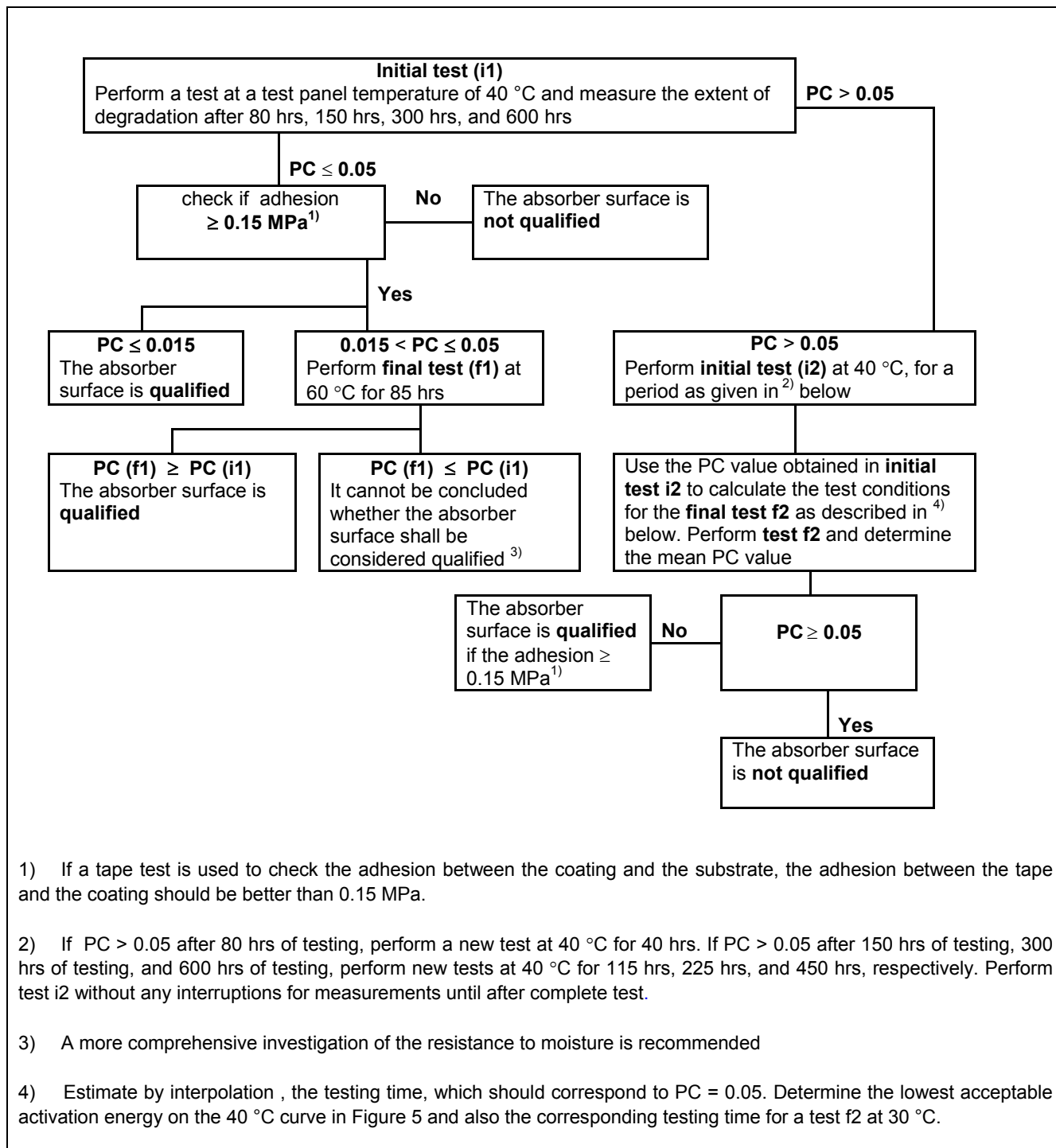

Figure C3 Test procedure for qualification of the resistance to condensed water of an solar absorber surface

Annex D (informative)

Suitable designs for test apparatus to be used in the qualification testing of solar absorber surface

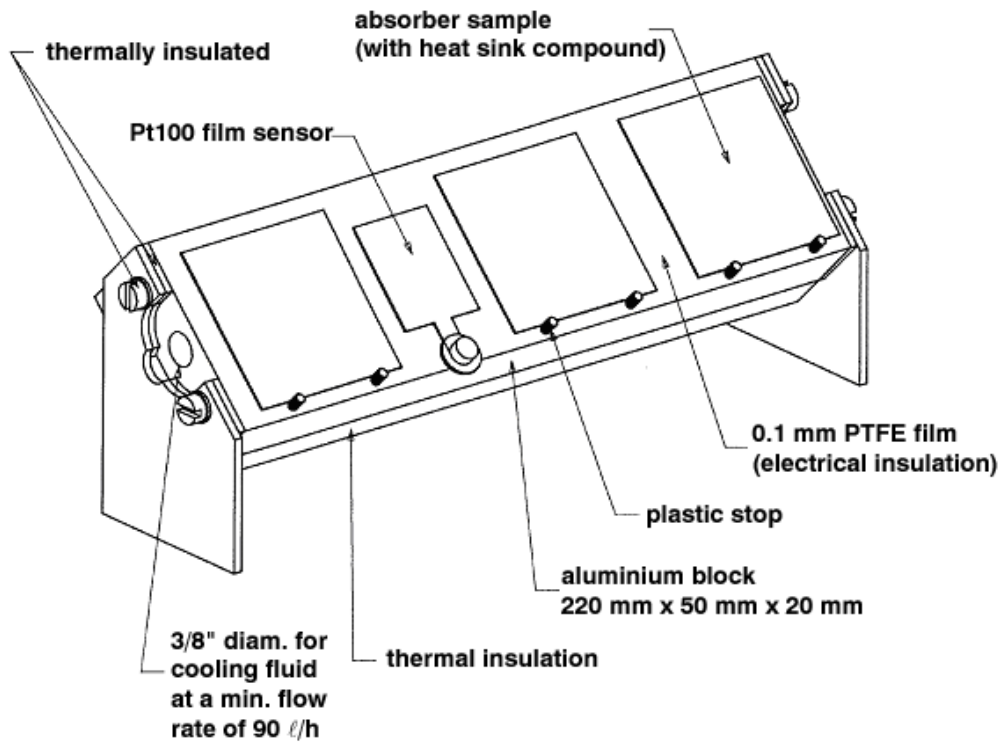
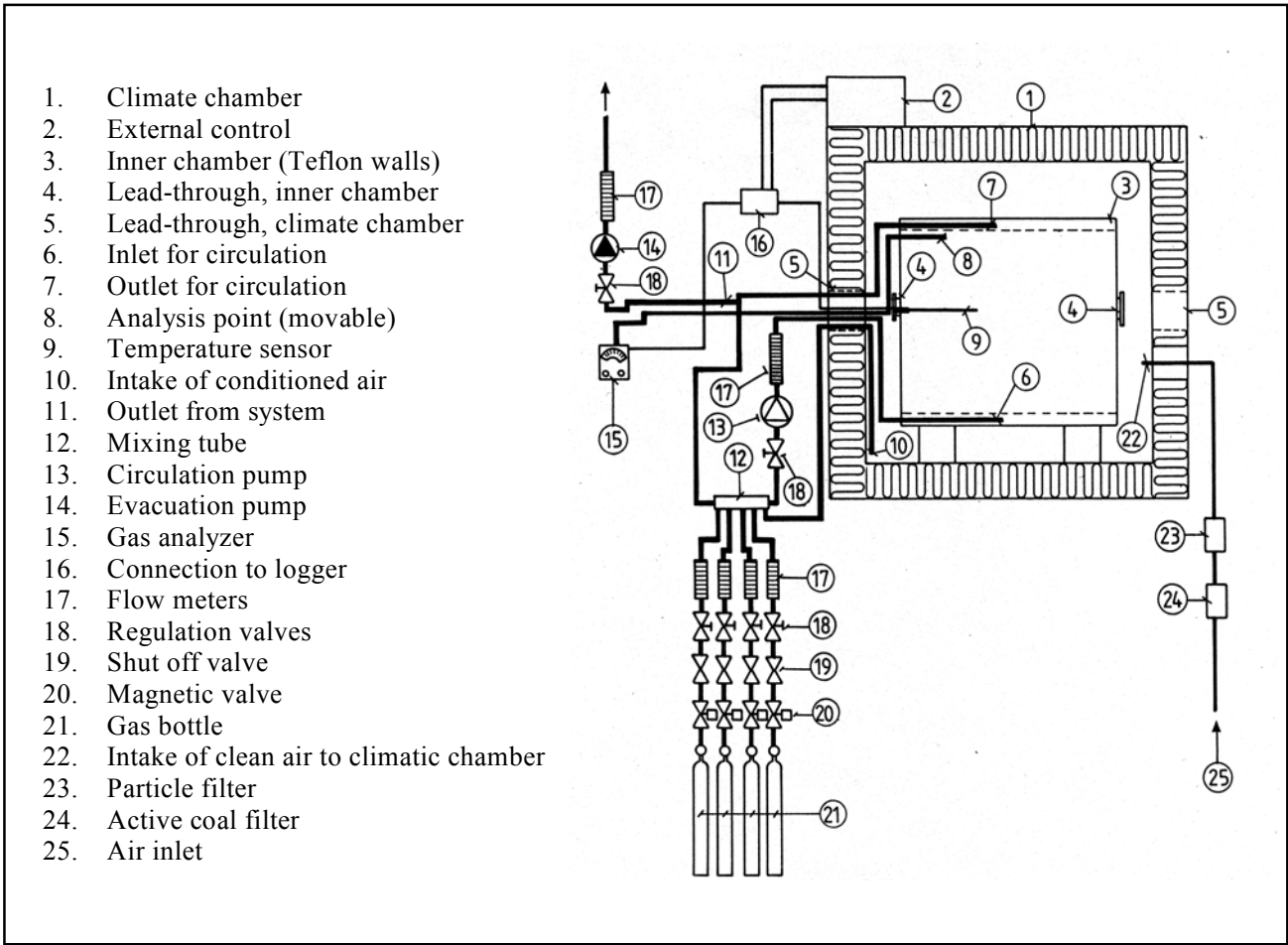

Figure D.1 Schematic drawing of suitable sample holder to be used for condensation testing. Samples are fastened to the PTFE-coated surface of the cooling block by aid of a heat sink compound.



1. Climate chamber
2. External control
3. Inner chamber (Teflon walls)
4. Lead-through, inner chamber
5. Lead-through, climate chamber
6. Inlet for circulation
7. Outlet for circulation
8. Analysis point (movable)
9. Temperature sensor
10. Intake of conditioned air
11. Outlet from system
12. Mixing tube
13. Circulation pump
14. Evacuation pump
15. Gas analyzer
16. Connection to logger
17. Flow meters
18. Regulation valves
19. Shut off valve
20. Magnetic valve
21. Gas bottle
22. Intake of clean air to climatic chamber
23. Particle filter
24. Active coal filter
25. Air inlet

Figure D2 Climatic cabinet suitable for use in corrosion tests involving exposure in high humidity air containing sulphur dioxide

Annex E (informative)

Bibliography

- [1] Accelerated Life Testing of Solar Energy Materials - Case study of some selective solar absorber for DHW systems; A Technical report of Task X Solar Materials Research and Development of the International Energy Agency Solar Heating and Cooling Program; B. Carlsson, U. Frei, M. Köhl, K. Möller; *SP-Report* 1994:13, ISBN 91-7848-472-3.
- [2] Qualification Test Procedure for Solar Absorber Surface Durability, Carlsson, B.; Möller, K.; Köhl, M.; Frei, U.; Brunold, S. (2000). *Solar Energy Materials and Solar Cells* 61, 225-275.
- [3] Accelerated Life Testing of Solar Absorber Coatings: Testing Procedure and Results. Brunold, S.; Frei, U.; Carlsson, B.; Möller, K.; Köhl, M.; (2000). *Solar Energy* 68, 313-323.
- [4] Comparison between Predicted and Actually Observed In-Service Degredation of a Nickel Pigmented Anodized Aluminium Absorber for Solar DHW Systems Carlsson, B.; Möller, K.; Frei, U.; Brunold, S.; Köhl, M.; (2000). *Solar Energy Materials and Solar Cells* 61, 223-238.
- [5] Round Robin on Accelerated Life Testing of Solar Absorber Surface Durability. Brunold, S.; Frei, U.; Carlsson, B.; Möller, K.; Köhl, M.; (2000). *Solar Energy Materials and Solar Cells* 61, 239-253.
- [6] Advanced procedure for the assessment of the lifetime of solar absorber coatings, M. Köhl, M. Heck, S. Brunold, U. Frei, B. Carlsson and K. Möller, *Solar Energy Materials and Solar Cells (in press)*
- [7] A study of the reflection factor of usual photometric standards in the near infrared; L. Morren, G. Vandermeersch, and P. Antoine; *Lighting Res. and Techn.* 4 (1972), 243